

QUEST® BAGGER

**For Serial Nos.
790,000 & Higher**
Part No. 4500-438 Rev. A

Operator's Manual

Exmark reserves the right to make changes or add improvements to its products at any time without incurring any obligation to make such changes to products manufactured previously. Exmark, or its distributors and dealers, accept no responsibility for variations which may be evident in the actual specifications of its products and the statements and descriptions contained in this publication.

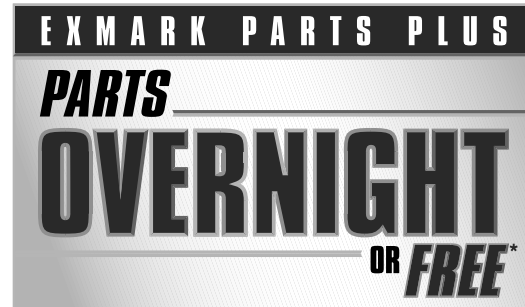

If your Exmark dealer does not have the Exmark part in stock, Exmark will get the parts to the dealer the next business day or the part will be FREE Guaranteed!! (Some restrictions apply. See your participating Exmark Dealer for details.)

Introduction

CONGRATULATIONS on the purchase of your Exmark Bagger. This product has been carefully designed and manufactured to give you a maximum amount of dependability and years of trouble-free operation.

This manual contains operating, maintenance, adjustment, and safety instructions for your Exmark Bagger.

BEFORE OPERATING YOUR MOWER, CAREFULLY READ THIS MANUAL IN ITS ENTIRETY.

By following the operating, maintenance, and safety instructions, you will prolong the life of your Bagger, maintain its maximum efficiency, and promote safe operation.

If additional information is needed, or should you require trained mechanic service, contact your authorized Exmark equipment dealer or distributor.

All Exmark equipment dealers and distributors are kept informed of the latest methods of servicing and are equipped to provide prompt and efficient service in the field or at their service stations. They carry ample stock of service parts or can secure them promptly for you from the factory.

All Exmark parts are thoroughly tested and inspected before leaving the factory, however, attention is required on your part if you are to obtain the fullest measure of satisfaction and performance.

Whenever you need service, genuine Exmark parts, or additional information, contact an Authorized Service Dealer or Exmark Customer Service and have the model and serial numbers of your product ready.

Figure 1 identifies the location of the model and serial numbers on the product. Write the numbers in the space provided.

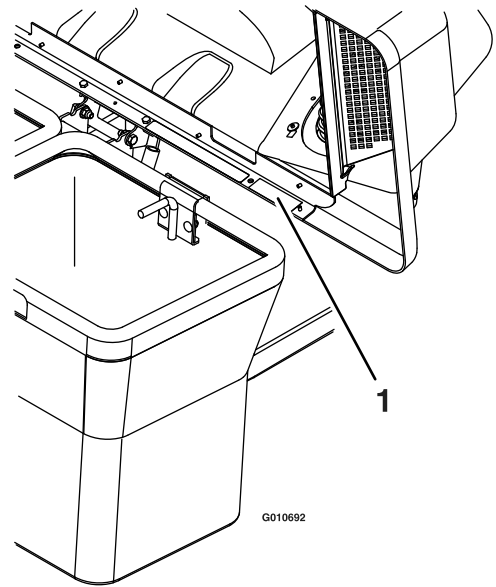

Figure 1

1. Model and serial number location

Model No. _____
Serial No. _____

Contents

Introduction	3
Safety	5
Safety Alert Symbol.....	5
Safe Operating Practices	5
Safety and Instructional Decals	8
Specifications	9
Model Numbers	9
Systems	9
Dimensions.....	9
Product Overview	10
Operation	10
Emptying the Grass Bags.....	10
Clearing Obstructions from the Bagger.....	10
Removing the Bagger	11
Replacing the Discharge Deflector	12
Installing the Bagger.....	12
Operating Tips	13
Transporting	14
Maintenance	16
Recommended Maintenance Schedule(s)	16
Periodic Maintenance	16
Inspecting the Bagger Attachment	16
Cleaning	17
Cleaning the Bagger Attachment.....	17
Storage	18
Storing the Bagger Attachment	18
Troubleshooting	19

Safety

Safety Alert Symbol

This Safety Alert Symbol (Figure 2) is used both in this manual and on the machine to identify important safety messages which must be followed to avoid accidents

This symbol means: **ATTENTION! BECOME ALERT! YOUR SAFETY IS INVOLVED!**



Figure 2

1. Safety alert symbol

The safety alert symbol appears above information which alerts you to unsafe actions or situations and will be followed by the word **DANGER**, **WARNING**, or **CAUTION**.

DANGER: White lettering / Red background. Indicates an imminently hazardous situation which, if not avoided, **Will** result in death or serious injury.

WARNING: Black lettering / Orange background. Indicates a potentially hazardous situation which, if not avoided, **Could** result in death or serious injury.

CAUTION: Black lettering / Yellow background. Indicates a potentially hazardous situation which, if not avoided, **May** result in minor or moderate injury.

This manual uses two other words to highlight information. **Important** calls attention to special mechanical information and **Note** emphasizes general information worthy of special attention.

Safe Operating Practices

Training

- Read the tractor and Bagger Operator's Manuals and other training material. If the operator(s) or mechanic(s) can not read English it is the owner's responsibility to explain this material to them.
- Become familiar with the safe operation of the equipment, operator controls, and safety signs.
- All operators and mechanics should be trained. The owner is responsible for training the users.

- Never let children or untrained people operate or service the equipment. Local regulations may restrict the age of the operator.
- The owner/user can prevent and is responsible for accidents or injuries occurring to himself or herself, other people or property.

Preparation

- Evaluate the terrain to determine what accessories and attachments are needed to properly and safely perform the job. Only use on machines approved by Exmark.
- Wear appropriate clothing including safety glasses, substantial footwear, long trousers, and hearing protection. Do Not operate when barefoot or when wearing open sandals.
- Inspect the area where the equipment is to be used and remove all rocks, toys, sticks, wires, bones, and other foreign objects which can be thrown by the machine and may cause personal injury to the operator or bystanders.

Operation

- Operate only in daylight or good artificial light, keeping away from holes and hidden hazards.
- Never remove the discharge tube, bags, bagger top or discharge deflector while the engine is running.
- Never do maintenance or repairs while the engine is running.
- Never mow with the discharge deflector raised, removed or altered unless there is a grass collection system or mulch kit in place and working properly.
- Stop engine, wait for all moving parts to stop, remove key and engage parking brake:
 - Before checking, cleaning or working on the mower.
 - After striking a foreign object or abnormal vibration occurs (inspect the mower for damage and make repairs before restarting and operating the mower).
 - Before clearing blockages.
 - Whenever you leave the mower.

Safety

- Stop the blades, slow down, and use caution when crossing surfaces other than grass and when transporting the mower to and from the area to be mowed.
- Be aware of the mower discharge path and direct discharge away from others.

Slope Operation

Use **Extreme** caution when mowing and/or turning on slopes as loss of traction and/or tip-over could occur. The operator is responsible for safe operation on slopes.

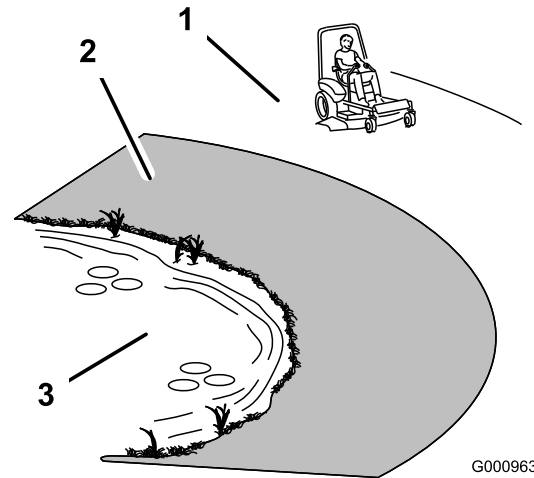

Figure 3

1. Safe Zone—Use the mower here on slopes less than 15 degrees
2. Danger Zone—Use walk behind mower and/or hand trimmer on slopes greater than 15 degrees, near drop-offs and water.
3. Water

⚠ DANGER

Operating on wet grass or steep slopes can cause sliding and loss of control. Wheels dropping over edges, ditches, steep banks, or water can cause rollovers, which may result in serious injury, death or drowning.

- Do Not mow slopes when grass is wet.
 - Do Not mow near drop-offs or near water.
 - Do Not mow slopes greater than 15 degrees.
 - Reduce speed and use extreme caution on slopes.
 - Avoid sudden turns or rapid speed changes.
- See inside the back cover to determine the approximate slope angle of the area to be mowed.
 - Use a walk behind mower and/or a hand trimmer near drop-offs, ditches, steep banks or water. (Figure 3).

- Remove or mark obstacles such as rocks, tree limbs, etc. from the mowing area. Tall grass can hide obstacles.
- Watch for ditches, holes, rocks, dips and rises that change the operating angle, as rough terrain could overturn the machine.
- Avoid sudden starts when mowing uphill because the mower may tip backwards.
- Be aware that operating on wet grass, across steep slopes or downhill may cause the mower to lose traction. Loss of traction to the drive wheels may result in sliding and a loss of braking and steering.
- Always avoid sudden starting or stopping on a slope. If tires lose traction, disengage the blades and proceed slowly off the slope.
- Follow the manufacturer's recommendations for wheel weights or counter weights to improve stability. Always install and remove the Bagger, including counter weights, as instructed. Failure to do so will cause a reduction in stability or traction. Do Not operate the mower with only a portion of the Bagger installed.
- Use extreme care with grass catchers or attachments. These can change the stability of the machine and cause loss of control. The stability and traction of the machine will change as the Bagger fills with grass clippings. Use progressively greater care on slopes as the Bagger fills.

Maintenance and Storage

- Disengage drives, set parking brake, stop engine and remove key or disconnect spark plug wire. Wait for all movement to stop before adjusting, cleaning or repairing.
- Use care when checking blades. Wrap the blade(s) or wear gloves, and use caution when servicing them. Only replace damaged blades. Never straighten or weld them.
- Keep all guards, shields and all safety devices in place and in safe working condition.
- Check all bolts frequently to maintain proper tightness.
- Frequently check for worn or deteriorating components that could create a hazard.
- All replacement parts must be the same as or equivalent to the parts supplied as original equipment.

Safety and Instructional Decals

- Keep all safety signs legible. Remove all grease, dirt and debris from safety signs and instructional labels.
- Replace all worn, damaged, or missing safety signs.
- When replacement components are installed, be sure that current safety signs are affixed to the replaced components.
- If an attachment or accessory has been installed, make sure current safety signs are visible.
- New safety signs may be obtained from your authorized Exmark equipment dealer or distributor or from Exmark Mfg. Co. Inc.
- Safety signs may be affixed by peeling off the backing to expose the adhesive surface. Apply only to a clean, dry surface. Smooth to remove any air bubbles.
- Familiarize yourself with the following safety signs and instruction labels. They are critical to the safe operation of your Exmark commercial mower.

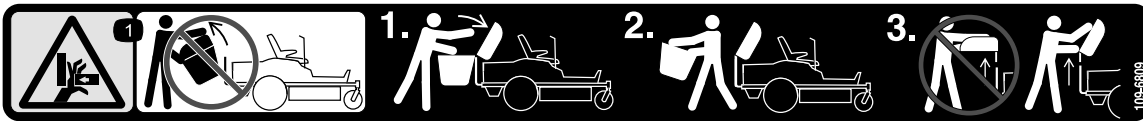

109-6809

1. Crushing hazard of hand—Do Not remove the whole bagger from the machine; open the bagger top and then remove the bag(s) from the bagger. Do Not remove the bagger top when it is closed; open the bagger top and then remove it.

Specifications

Model Numbers

Serial Nos: 790,000 and Higher
116-1084

Systems

Bagging System

- Collection Bins:
 - Commercial grade, cloth mesh bags with reinforced bottoms.
 - Capacity: 6 bushels (2 bags and hood)
- Dump Mechanism: Manual lift off
- Blower Tube: Fixed, abrasion resistant molded polyethylene.

Recommended High Lift Blades:

	Part Number
42 inch Deck	116-1202
48 inch Deck	109-6391
52 inch Deck	109-6392

These blades are recommended to obtain maximum air flow to the bag.

Dimensions

Overall Width:

	w/Bagger
42 inch Deck	53.0 inches (135 cm)
48 inch Deck	57.0 inches (145 cm)
52 inch Deck	60.0 inches (152 cm)

Overall Length:

	w/Bagger
42 inch Deck	95 inches (241 cm)
48 inch Deck	95 inches (241 cm)
52 inch Deck	95 inches (241 cm)

Overall Height:

	w/Bagger
42 inch Deck	44.5 inches (113 cm)
48 inch Deck	44.5 inches (113 cm)
52 inch Deck	44.5 inches (113 cm)

Curb Weight:

125 lb (57 kg) including front weight.

Product Overview

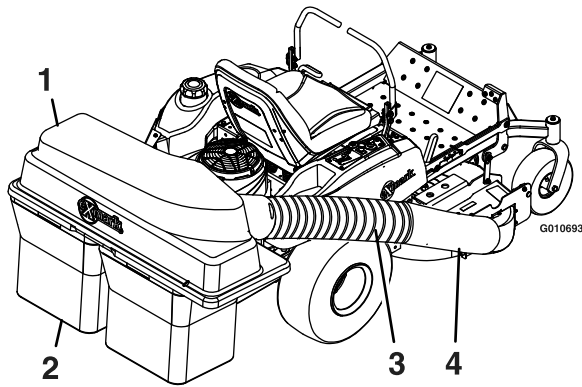

Figure 4

- | | |
|---------|------------------------|
| 1. Hood | 3. Upper flexible tube |
| 2. Bag | 4. Lower tube |

Operation

Note: Determine the left and right sides of the machine from the normal operating position.

Emptying the Grass Bags

Be careful when lifting or handling a grass bag that is full. To empty the grass bags:

1. Move the motion control levers outward to neutral position, disengage the power take off (PTO), engage parking brake, stop the engine, remove the key, and wait for all moving parts to stop before leaving the operating position.
2. Open (raise) the hood.
3. Compress debris into the bags. With both hands, lift up on the bag and unhook it from the retaining bracket. Empty the bag. Repeat the procedure for the other bag.
4. Install the bags by sliding the bag frame hook onto the retaining bracket (Figure 5).

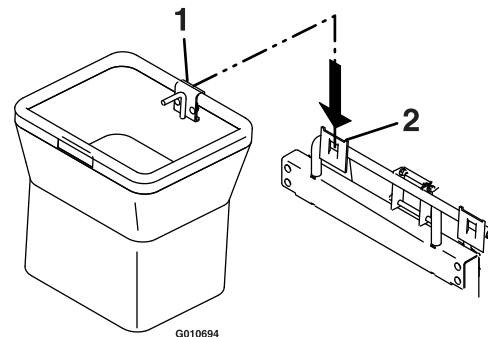

Figure 5

- | | |
|-------------------|----------------------|
| 1. Bag frame hook | 2. Retaining bracket |
|-------------------|----------------------|

5. Lower the hood onto the bags.

Clearing Obstructions from the Bagger

1. Move the motion control levers outward to neutral position, disengage the power take off (PTO), engage parking brake, stop the engine, remove the key, and wait for all moving parts to stop before leaving the operating position.
2. Check the grass bags and empty them if they are full.
3. Remove and separate the discharge tube and chute from the bagger hood and mower. Using a stick or similar object, carefully remove and clear

the obstruction from the mower, discharge tube, chute, and the hood.

4. After you remove the obstruction, install the complete bagger system and resume operation.

Removing the Bagger

⚠ DANGER

An uncovered discharge opening will allow objects to be thrown in operator's or bystander's direction. Also, contact with blade could occur. Thrown objects or blade contact can cause serious injury or kill you or bystanders.

Never operate mower unless discharge deflector, or entire grass collection system, or mulch kit is installed.

1. Move the motion control levers outward to neutral position, disengage the power take off (PTO), engage parking brake, stop the engine, remove the key, and wait for all moving parts to stop before leaving the operating position.
2. Remove the upper flexible tube from the hood junction tube.

⚠ WARNING

Operating the mower with the bagger installed and the front weight removed may cause loss of traction and steering control or an unstable condition which could result in injury or death.

Install the bagger only when the front weight is installed.

3. Remove the bagger mount bracket from the deck and retain all hardware see Figure 6.

Note: The boot mount bracket does not have to be removed from the deck.

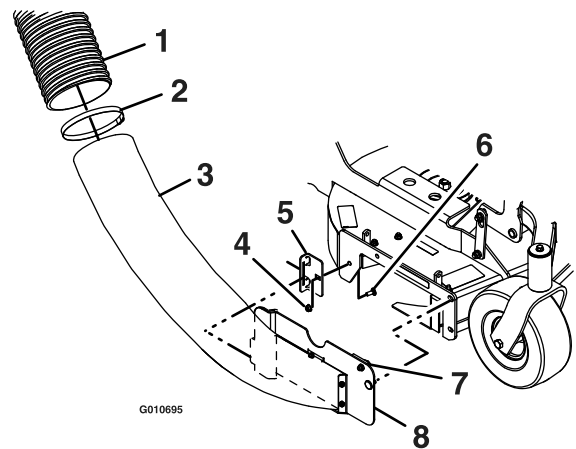

Figure 6

- | | |
|------------------------|-----------------------|
| 1. Upper flexible tube | 5. Boot mount bracket |
| 2. Clamp | 6. Bolt |
| 3. Lower tube | 7. Latch |
| 4. Nut | 8. Mount bracket |

⚠ CAUTION

If you remove the spring-loaded hood when it is closed (in the down position), the hood may suddenly fly open and you or someone else may be bruised, pinched, or injured in another way.

Always open (raise) the hood before you remove or install it on the quick-attach bracket.

4. Open the hood and remove the two bags from the bag frame hooks (Figure 5).
5. Lift the bagger mount assembly and hood off the bagger hitch.

Note: The bagger hitch does not have to be removed from the unit.

Note: The removable weight is heavy. Use care when lifting it. Make sure that you can hold it securely before lifting it. Use caution when positioning your hands so that you Do Not set it down on your hands or fingers.

6. Remove the weight on the front of the mower.

Note: The weight support assembly can stay mounted to the unit when the bagger and weight are removed.

7. Store all hardware in a convenient location.

Operation

Note: On the 42 and 52 inch decks, the discharge baffle does not have to be removed from the deck; you may notice better discharge with it installed. If removed, replace the original hardware in the deck holes.

Replacing the Discharge Deflector

1. Locate items shown in Figure 7.

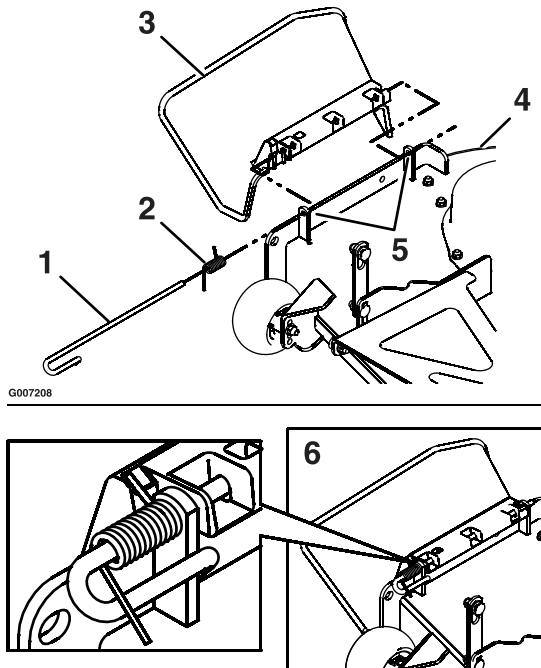

Figure 7

- | | |
|------------------------|--------------------------------|
| 1. Rod | 4. Mower deck |
| 2. Spring | 5. Discharge deflector bracket |
| 3. Discharge deflector | 6. Assembled view |

2. Place the discharge deflector on the deck.
3. Orient the spring so that the short leg points towards the discharge deflector and the longer leg points towards the deck as shown in Figure 7. Place spring on rod and slide rod, straight end, through the front discharge deflector bracket, discharge deflector, and rear deflector bracket.
4. Make sure that the spring and rod are installed so that the rod is retained from sliding out by the front bracket and the spring holds the discharge deflector in the down position. Refer to (Figure 7) for proper orientation.

Important: The discharge deflector must be spring loaded in the down position. Lift the

deflector up to test that it snaps to the full down position.

Installing the Bagger

1. Move the motion control levers outward to neutral position, disengage the power take off (PTO), engage parking brake, stop the engine, remove the key, and wait for all moving parts to stop before leaving the operating position.
2. Slide the rod out of the short stand-off, spring, and discharge deflector. Remove the discharge deflector (see Figure 7).
3. Install the hood assembly onto the hitch.
4. Install the bags by sliding the bag frame hook onto the retaining bracket (see Figure 8).

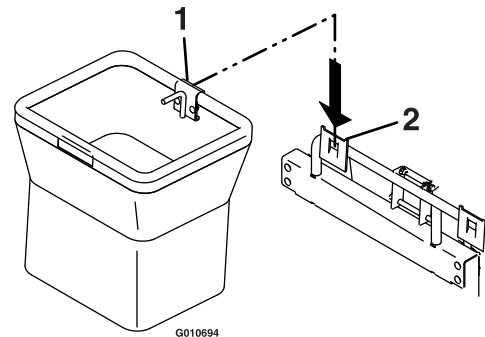

Figure 8

- | | |
|-------------------|----------------------|
| 1. Bag frame hook | 2. Retaining bracket |
|-------------------|----------------------|

5. Lower the hood onto the bags.
6. Insert the mount bracket tab on the lower tube assembly into the boot mount bracket as shown in Figure 6.
7. Use the latch on the lower tube assembly to lock the bracket to the deck. Adjust the tension on the latch to hold the bracket up to the deck, yet allow for release by hand.
8. Slip the upper flexible tube into junction tube of the hood opening.
9. Install the front weight. The lock rod has a key on one end. Slide the lock rod through the weight support assembly, notch in the weight and the oval hole in the frame bracket.
10. Rotate the lock rod to secure it into place.

⚠ WARNING

The front weight installed without the bagger may cause loss of traction and steering control or an unstable condition which could result in injury or death.

Install the front weight only when the bagger is installed.

Note: The removable weight is heavy. Use care when lifting it. Make sure that you can hold it securely before lifting it. Use caution when positioning your hands so that you Do Not set it down on your hands or fingers.

11. Install the bagger blades. Refer to the mower operator's manual for blade installation.

Note: Original equipment blades can be used; however high lift blades are recommended for best performance.

⚠ WARNING

Incorrect installation of the blade or components used to retain the blade cause the blade to come loose and could seriously injure or kill you or bystanders.

Always install the original Exmark blades, washers and blade bolts as shown in the mower Operator's manual.

Operating Tips

Larger Machine with Bagger

Remember that the mower is longer and wider with this attachment installed. By turning too sharply in confined places you may damage the attachment.

Maintenance

For best cut quality, be sure to check the deck leveling and blade slope (rake). See the tractor Operator's manual.

Trimming

Always trim with the left side of the mower. Do Not trim with the right side of the mower because you could damage the bagger's chute and discharge tube.

Cutting Height

Do Not set the mower cutting height too low because long grass surrounding the mower can prevent air from getting under the mower and entering the bagging system. If enough air doesn't get under the mower, the bagging system will plug.

Cutting Frequency

Cut the grass often, especially when it grows rapidly. You will have to cut your grass twice if it gets excessively long.

Cutting Technique

For best lawn appearance, be sure to slightly overlap the mower into the previously cut area. This helps reduce the load on the engine and reduces the chance of plugging the chute and discharge tube.

Using Bag Liners

Although not required, bag liners may be inserted into each grass bag to collect clippings and make disposal more convenient (Figure 9). If you use a bag liner, remove the filled grass bag and close the top of the liner. Then pull the liner out of the grass bag or turn the bag upside down while holding the handle on the bottom of the grass bag, allowing the liner to slide out.

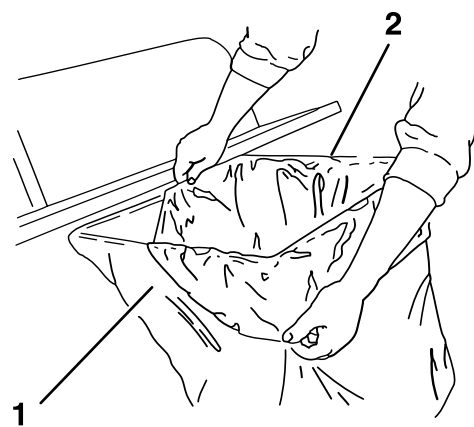

Figure 9

1. Cloth grass bag
2. Bag liner

Bagging Speed

Most often you will bag with the mower throttle in the Fast position and drive at a normal ground speed. However, in extremely dry and dusty grass, you may

Operation

want to slightly reduce the throttle speed and increase the ground speed of the mower. The bagging system may plug if you drive too fast and the engine speed gets too slow. On hills it may be necessary to slow the mower ground speed. This helps maintain the engine speed and bagging efficiency.

⚠ CAUTION

As the bagger fills, extra weight is added to the back of the machine. If you stop and start suddenly on hills, you may lose steering control or the machine may tip.

- **Do Not start or stop suddenly when going uphill or downhill. Avoid uphill starts.**
- **If you do stop the machine when going uphill, disengage the blade control switch. Then back down the hill using a slow speed.**
- **Do Not change speeds or stop on slopes.**

Bagging Long Grass

Excessively long grass is heavy and may not be propelled completely into the grass bags. If this happens, the discharge tube and chute may plug. To avoid plugging the bagging system, mow the grass at a high height of cut, then lower the mower to your normal cutting height and repeat the bagging process.

Bagging Wet Grass

Always try to cut grass when it is dry because your lawn will have a neat appearance. If you must cut wet grass, use the conventional side discharge feature of the mower. Several hours later, when the clippings are dry, install the complete bagger attachment and vacuum up the grass clippings.

Signs of Plugging

As you are bagging, a small amount of grass clippings normally blow out the front of the mower. An excessive amount of clippings blowing out indicates that the bags are full or the system is plugged.

Transporting

Transporting a Unit

Use a heavy-duty trailer or truck to transport the machine. Lock brake and block wheels. Securely fasten the machine to the trailer or truck with straps, chains, cable, or ropes. Be sure that the trailer or truck has all necessary lighting and marking as required by law. Secure a trailer with a safety chain.

⚠ CAUTION

This unit does not have proper turn signals, lights, reflective markings, or a slow moving vehicle emblem. Driving on a street or roadway without such equipment is dangerous and can lead to accidents causing personal injury. Driving on a street or roadway without such equipment may also be a violation of State laws and the operator may be subject to traffic tickets and/or fines.

Do Not drive a unit on a public street or roadway.

WARNING

Loading a unit on a trailer or truck increases the possibility of backward tip-over. Backward tip-over could cause serious injury or death.

- Use extreme caution when operating a unit on a ramp.
- Use only a single, full width ramp; Do Not use individual ramps for each side of the unit.
- If individual ramps must be used, use enough ramps to create an unbroken ramp surface wider than the unit.
- Do Not exceed a 15° angle between ramp and ground or between ramp and trailer or truck.
- Avoid sudden acceleration while driving unit up a ramp to avoid tipping backward.
- Avoid sudden deceleration while backing unit down a ramp to avoid tipping backward.

ramp angle. The trailer or truck should be as level as possible.

Important: Do Not attempt to turn the unit while on the ramp, you may lose control and drive off the side.

Avoid sudden acceleration when driving up a ramp and sudden deceleration when backing down a ramp. Both maneuvers can cause the unit to tip backward.

Loading a Unit

Empty grass bags before attempting to load unit on trailer or truck. Use extreme caution when loading units on trailers or trucks. One full width ramp that is wide enough to extend beyond the rear tires is recommended instead of individual ramps for each side of the unit. The lower rear section of the tractor frame extends back between the rear wheels and serves as a stop for tipping backward. Having a full width ramp provides a surface for the frame members to contact if the unit starts to tip backward. If it is not possible to use one full width ramp, use enough individual ramps to simulate a full width continuous ramp.

Ramp should be long enough so that the angles between the ramp and the ground and the ramp and the trailer or truck do not exceed 15°. A steeper angle may cause mower deck components to get caught as the unit moves from ramp to trailer or truck. Steeper angles may also cause the unit to tip backward. If loading on or near a slope, position the trailer or truck so it is on the down side of the slope and the ramp extends up the slope. This will minimize the

Maintenance

Note: Determine the left and right sides of the machine from the normal operating position.

⚠ WARNING

While maintenance or adjustments are being made, someone could start the engine. Accidental starting of the engine could seriously injure you or other bystanders.

Remove the key from the ignition switch, engage parking brake, and pull the wire(s) off the spark plug(s) before you do any maintenance. Also push the wire(s) aside so it does not accidentally contact the spark plug(s).

⚠ WARNING

Debris built up in the engine compartment, if not removed, could be ignited by a hot engine. A fire in the engine compartment can burn you and others and can damage property.

- Before using and while the engine is cool, check for debris in the engine compartment.
- Keep the machine free of grass, leaves, or other debris build-up.
- Clean up oil or fuel spillage and fuel soaked debris.
- Allow the machine to cool before storing.

Recommended Maintenance Schedule(s)

Maintenance Service Interval	Maintenance Procedure
After the first 10 hours	<ul style="list-style-type: none">• Check the bagger attachment.
Before each use or daily	<ul style="list-style-type: none">• Clean the bagger attachment.
Monthly	<ul style="list-style-type: none">• Check the bagger attachment.
Yearly or before storage	<ul style="list-style-type: none">• Clean the bagger attachment.

Periodic Maintenance

Inspecting the Bagger Attachment

**Service Interval: After the first 10 hours
Monthly thereafter.**

1. Check the chute, discharge tube, and the bagger top. Replace these parts if they are cracked or broken.
2. Tighten all nuts, bolts, and screws.
3. Under normal use the bags will deteriorate and wear. Inspect the grass bags for deterioration.

⚠ WARNING

You or bystanders could be severely injured by flying debris or thrown objects that may pass through torn, worn or deteriorated grass bags.

- Frequently check the grass bags for holes, rips, wear, and other deterioration.
- Do not wash the grass bags.
- If the bag has deteriorated, install new grass bags supplied by the manufacturer of this bagger attachment.

Inspecting the Mower Blades

Service Interval: As required

Refer to your mower Operator's Manual for complete blade maintenance.

Caring for the Grass Bags

Service Interval: As required

Washing the grass bags is not recommended.

Under normal use the bags will deteriorate and wear. To prevent rapid deterioration of the bag material, store the bags where they will dry completely after each use.

Cleaning

Cleaning the Bagger Attachment

Service Interval: Before each use or daily

1. After each use, remove and wash the inside and outside of the bagger top, discharge tube, chute, and the underside of the mower, using water sprayed from a garden hose. Use a mild automotive detergent to remove stubborn dirt.
2. Make sure you remove matted grass from all parts
3. After washing, let all of the parts dry thoroughly. Do Not wash the grass bags.

Storage

Storing the Bagger Attachment

1. Clean the bagger attachment; refer to **Cleaning the Bagger Attachment** in Maintenance.
2. Inspect the bagger attachment for damage; refer to **Inspecting the Bagger Attachment** in Maintenance.
3. Make sure the grass bags are empty and thoroughly dry.
4. Store the bagger in a clean, dry place, out of direct sunlight. This protects the plastic parts and extends the life of the bagger. If you must store the bagger outside, cover it with a weatherproof cover.

Troubleshooting

Important: It is essential that all operator safety mechanisms be connected and in proper operating condition prior to mower use.

When a problem occurs, do not overlook the simple causes. For example: starting problems could be caused by an empty fuel tank.

The following table lists some of the common causes of trouble. Do Not attempt to service or replace major items or any items that call for special timing or adjustment procedures (such as valves, governor, etc.). Have this work done by your **Engine Service Dealer**.

Note: When disconnecting electrical connectors Do Not pull on the wires to separate the connectors.

Problem	Possible Cause	Corrective Action
Excessive grass blowout from the deck.	<ol style="list-style-type: none"> 1. Bags are full. 2. Plugged screen in bagger hood. 3. Ground speed is too fast. 4. Plugged tube. 5. Conditions are dry. 	<ol style="list-style-type: none"> 1. Dump more frequently. 2. Remove debris, leaves or grass clippings from the screen. 3. Drive slower at full throttle. 4. Locate and remove plugged debris. 5. Use lower lift blade or reduce engine speed.
Tubes plug too frequently.	<ol style="list-style-type: none"> 1. Bags are too full. 2. Ground speed is too fast. 3. Grass is too wet. 4. Grass is too long. 5. Plugged screen in bagger hood. 6. Plugged tube. 	<ol style="list-style-type: none"> 1. Dump more frequently 2. Drive slower at full throttle. 3. Cut grass when it is dry. 4. Cut grass more frequently or at higher cut height. 5. Remove debris, leaves, or grass clippings from the screen. 6. Use recommended high lift blades.

Exmark Quest Attachments and Accessories

1-Year Limited Consumer Warranty (30-Day Limited Commercial Warranty)

Consumer Warranty Conditions and Products Covered

Exmark Mfg. Co. Inc. and its affiliate, Exmark Warranty Company, pursuant to an agreement between them, jointly warrant on the terms and conditions herein, that we will repair, replace or adjust any part on these products and found by us (in the exercise of our reasonable discretion) to be defective in factory materials or workmanship for a period of one year for residential usage of Exmark Quest attachments and accessories.

Residential usage means use of the product on the same lot as your home. Use at more than one location is considered commercial use, and the commercial use warranty detailed below would apply.

This warranty applies to Exmark Quest attachments and accessories sold in the U.S. or Canada. This warranty may only be assigned or transferred to a second (or third) owner by an authorized Exmark dealer. The warranty period commences upon the date of the original retail purchase.

Warranty Exceptions

- Bags, Belts and Tires

Warranty Period

90 days

This warranty only includes the cost of parts and labor.

Limited Warranty for Commercial Use

Exmark Quest attachments and accessories used for commercial, institutional, or rental use are warranted against defects in materials or workmanship for a period of 30 days from the date of original purchase.

Items and Conditions Not Covered

This warranty does not cover the following:

- Pickup and delivery charges to and from any authorized Exmark Service Dealer.
- Any damage or deterioration due to normal use, wear and tear, or exposure.
- Cost of regular maintenance service or parts, such as filters, fuel, lubricants, tune-up parts, and adjustments.
- Any product or part which has been altered or misused or required replacement or repair due to normal wear, accidents, or lack of proper maintenance.
- Any repairs necessary due to use of parts, accessories or supplies, including gasoline, oil or lubricants, incompatible with the attachments and accessories or other than as recommended in the operator's manual or other operational instructions provided by Exmark.

All warranty work must be performed by an authorized Exmark Service Dealer using Exmark approved replacement parts.

Instructions for Obtaining Warranty Service

The product must be registered with original proof of purchase by an Exmark Service Dealer before obtaining any warranty service.

Contact any Exmark Service Dealer to arrange service at their dealership. To locate a dealer convenient to you, access our website at www.exmark.com. U.S. or Canada customers may also call 402-223-6375.

If for any reason you are dissatisfied with the Service Dealer's analysis or with the assistance provided, contact us at:

Exmark Customer Service Department
The Exmark Warranty Company
2101 Ashland Avenue
Beatrice, NE 68310
402-223-6375 or
service@exmark.com

Owner's Responsibilities

The Exmark attachment or accessory, including any defective part, must be returned to an authorized Exmark service dealer within the warranty period. This warranty extends only to Quest attachments and accessories operated under normal conditions. You must read the operator's manual. You must also properly service and maintain your Exmark product as described in the operator's manual or other operational instructions provided by Exmark. Such routine maintenance, whether performed by a dealer or by you, is at your expense.

General Conditions

The sole liability of Exmark and Exmark Warranty Company with respect to this warranty shall be repair or replacement of defective components as set forth herein. **Neither Exmark nor Exmark Warranty Company shall be liable for any incidental or consequential loss or damage.**

Such damages include but are not limited to:

- Expenses related to gasoline, oil or lubricants.
- Travel time, overtime, after hours time or other extraordinary repair charges or charges relating to repairs or replacements outside of normal business hours at the place of business of the authorized Exmark Service Dealer.
- Rental of like or similar replacement equipment during the period of any warranty, repair or replacement work.
- Any telephone or telegram charges or travel charges.
- Loss or damage to person or property other than that covered by the terms of this warranty.
- Any claims for lost revenue, lost profit or additional cost as a result of a claim of breach of warranty.
- Attorney's fees.

No Claim of breach of warranty shall be cause for cancellation or rescission of the contract of sale of any Exmark mower.

All implied warranties of merchantability (that the product is fit for ordinary use) and fitness for use (that the product is fit for a particular purpose) are limited to the duration of the express warranty.

Some states do not allow exclusions of incidental or consequential damages, or limitations on how long an implied warranty lasts, so the above exclusions and limitations may not apply to you.

This warranty gives you specific legal rights, and you may also have other rights which vary from state to state.

G4500-429

Notes:

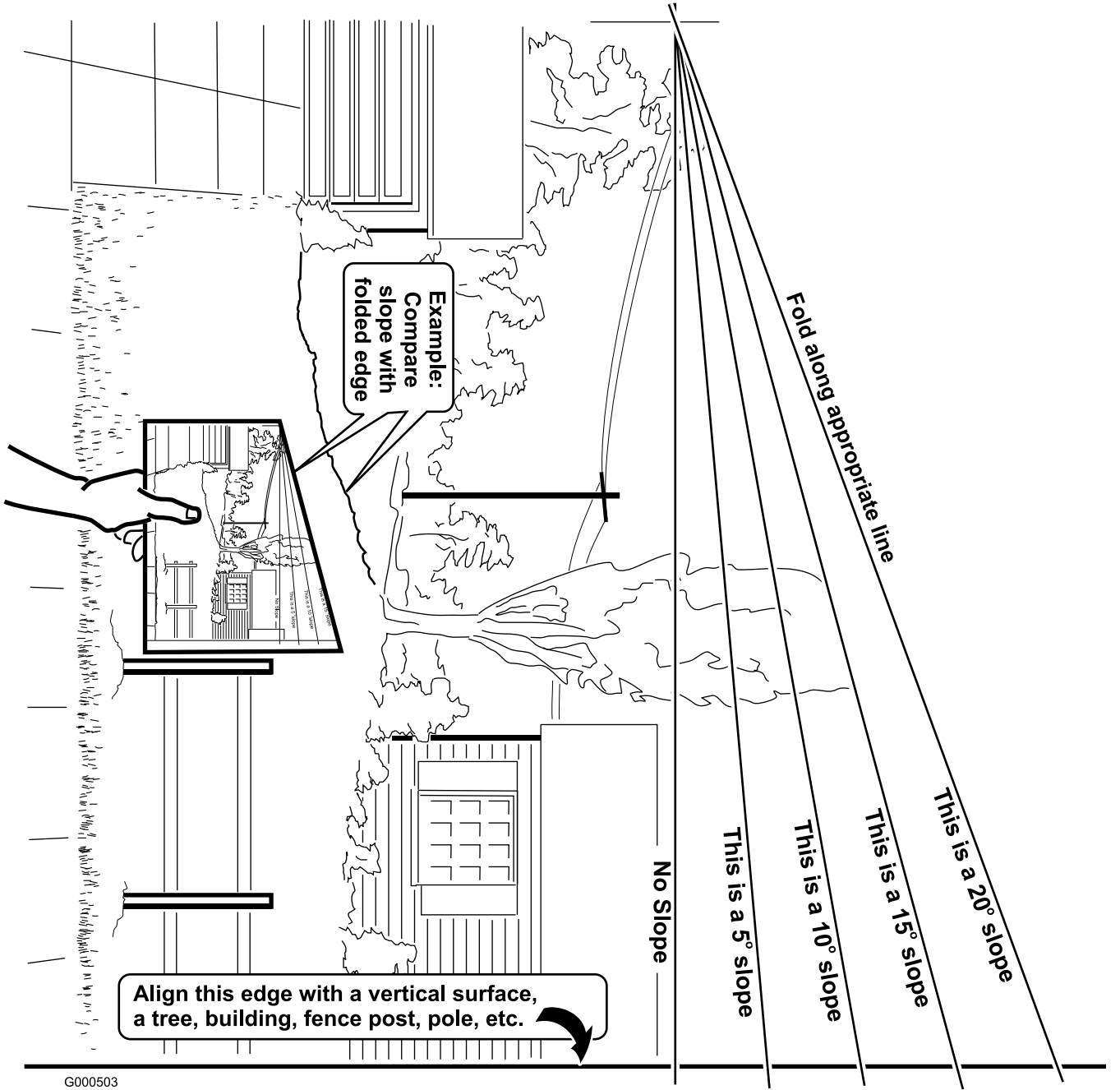

G000503

SEE EXMARK'S COMPLETE LINE OF ACCESSORIES AND OPTIONS

MID-MOUNT RIDING ACCESSORIES AND OPTIONS

CUSTOM RIDE SEAT SUSPENSION SYSTEM	OPERATOR CONTROLLED DISCHARGE
FULL SUSPENSION SEAT	ROLL OVER PROTECTION SYSTEM (ROPS)
DECK LIFT ASSIST KIT	SUN SHADE
HITCH KIT	TRASH CONTAINER
LIGHT KIT	TURF STRIPER
12V POWER PORT	ULTRA VAC COLLECTION SYSTEM
MICRO-MULCH SYSTEM	ULTRA VAC QUICK DISPOSAL SYSTEM

OUT-FRONT RIDING ACCESSORIES AND OPTIONS

CUSTOM RIDE SEAT SUSPENSION SYSTEM	SNOW BLADE
DUAL-TAIL WHEEL	SNOWBLOWER
FLOOR PAN EXTENDER	SUN SHADE
HITCH KIT	TRASH CONTAINER
LIGHT KIT	ULTRA VAC COLLECTION SYSTEM
MICRO-MULCH SYSTEM	ULTRA VAC QUICK DISPOSAL SYSTEM
ROLL OVER PROTECTION SYSTEM (ROPS)	WEATHER CAB

WALK-BEHIND ACCESSORIES AND OPTIONS

GRASS CATCHER	TURF STRIPER
MICRO-MULCH SYSTEM	STANDON

Place Model No. and Serial No.
Label Here (Included in the Literature
Pack) or Fill in Below

Model No. _____

Serial No. _____

Date Purchased _____

© 2009 Exmark Mfg. Co., Inc.
Industrial Park Box 808
Beatrice, NE 68310
All Rights Reserved

Part No. 4500-438 Rev. A
(402) 223-6300
Fax (402) 223-5489
Printed in the USA

